

## SPECIFICATIONS

<b>Type</b>	Double Sided 200mm Deep	
<b>Where to fix</b>	Fixed in between two posts	
<b>LED Source</b>	LED Modules SA 4161 Equivalent from SA-LED Australia	
<b>Power Source</b>	Suitable Power Supply from SA-LED Australia	
<b>Dimension</b>	Length	Any Size
	Height	Up to 1,500mm
	Deep	200mm
		*Post deep : Max 150mm
<b>Face</b>	4.5mm Opal Acrylic	
<b>Return</b>	Aluminum Extrusion Bar - Mill(2B) Finish - White or Black - 2Pac Spray (Other colours)	
<b>Back</b>	ACM or Equivalent Material	
<b>Cover Size</b>	25 / 40 / 50mm	Removable Angle Trim

- Price do not include acrylic sheets.
- Price do not include packaging and delivery
- Artwork has to be provided by the client.
- Please make sure to include the original artwork files that is:

- ✓ 1:1 Scale
- ✓ 100% Vector(\*.eps)
- ✓ PDF File format (\*.pdf)
- ✓ CorelDRAW (\*.cdr, \*.dxf)

## 3D STRUCTURE

Front View

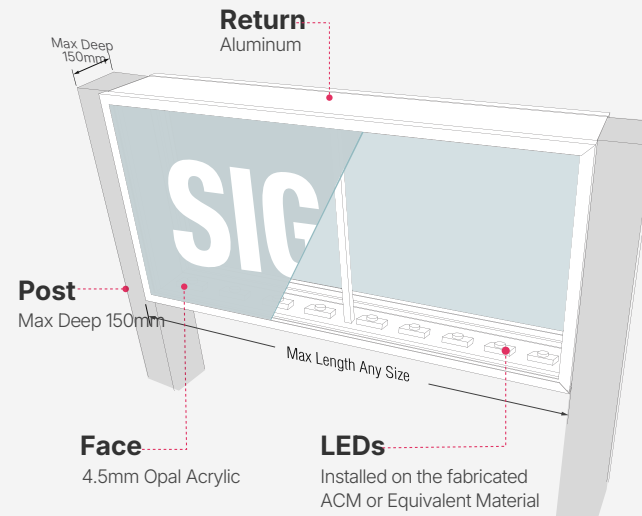

Side View

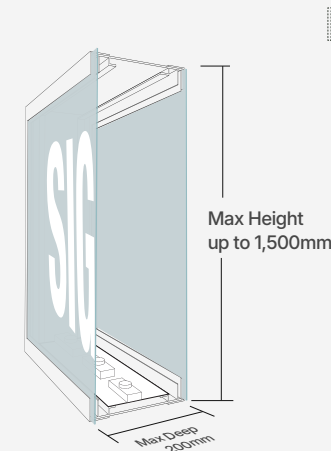

Side View : Fixed in between two posts

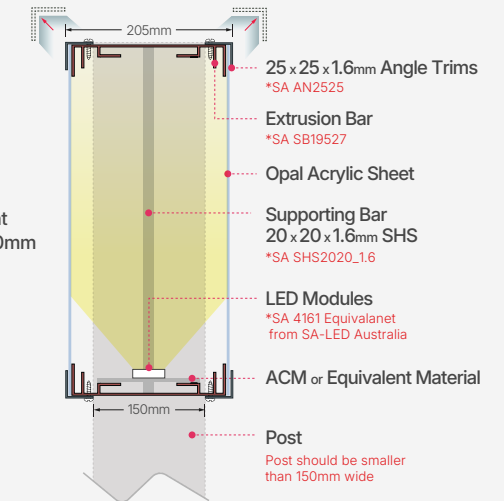

\*All LED modules, power suppliers, extrusion bars, angle trims and other bars can be purchased in [www.SA-LED.com](http://www.SA-LED.com)

## INSTALLATION GUIDE

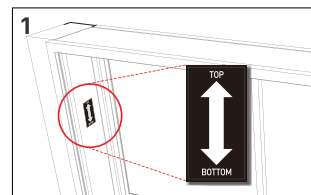

TOP & BOTTOM indicative sticker at the inside.

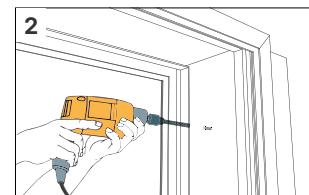

Fixed directly into post.

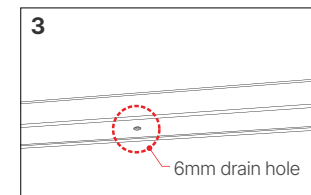

Predrilled 6mm drain holes on bottom.

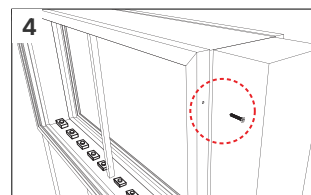

Remove screw from angle trims for insert acrylic.

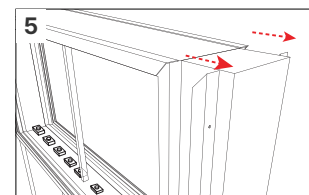

Remove angle trim from lightbox.

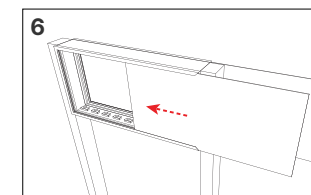

Insert acrylic face into body frame.

## PROJECTS

